

STANDARD FEATURES

- All Stainless Steel Construction
- External Recalibration Adjustment
- White dial with black markings
- Accurate to ±1% of Scale Range
- Gasketed Glass Face
- Case is sealed to exclude dirt, dust and moisture
- 5" dial size

STEM LENGTH	CATALOG NUMBERS*			
	90° BACK ANGLE FORM	STRAIGHT FORM	90° LEFT SIDE ANGLE FORM	90° RIGHT SIDE ANGLE FORM
2½"	3A02	3S02	3L02	3R02
4"	3A04	3S04	3L04	3R04
6"	3A06	3S06	3L06	3R06
9"	3A09	3S09	3L09	3R09
12"	3A12	3S12	3L12	3R12
15"	3A15	3S15	3L15	3R15
18"	3A18	3S18	3L18	3R18
24"	3A24	3S24	3L24	3R24

Longer stem lengths available on special order (48" maximum on straight, left and right side forms; 72" on back angle)

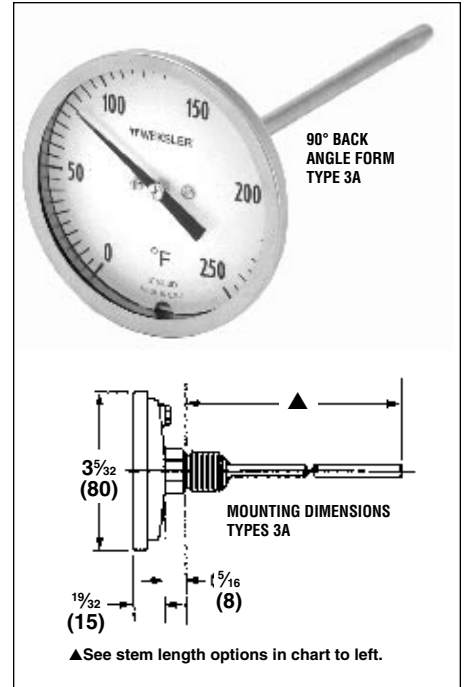

STANDARD RANGES

CODE	Fahrenheit
FC	-80 to 120°F
FE	-40 to 120°F
FG	0 to 150°F
FJ	0 to 200°F
FL	0 to 250°F
FM	30 to 240°F
FN	25 to 125°F
FR	50 to 300°F
FS	50 to 400°F
FT	50 to 550°F
FX	150 to 750°F†
FY	200 to 1000°F*†

CODE	Celsius
CD	-50 to 50°C
CJ	0 to 100°C
CM	-10 to 110°C
CN	0 to 50°C
CR	0 to 150°C
CS	0 to 200°C
CU	0 to 300°C
CX	50 to 450°C†
CY	100 to 550°C*†

CODE	DUAL SCALE	
	Fahrenheit (on outside)	Celsius (on inside)
DE	-40/120°F and	-40/50°C
DF	40/160°F and	-40/70°C
DN	30/130°F and	0/55°C
DJ	0/200°F and	-20/94°C
DL	0/250°F and	-20/120°C
DR	50/300°F and	10/150°C
DS	50/400°F and	10/200°C
DT	50/550°F and	10/290°C
DX	100/800°F* and	40/430°C†
DY	200/1,000°F and	100/550°C*†

*Not recommended for continuous service above 800°F (425°C). For such temperatures see pg. 63.
 †Minimum stem length for these ranges 4".

OPTIONAL FEATURES	
CODE	Description
EL	Liquid Filling for Catalog No's AF, 3A, 5A only
PD	Plastic Window
SG	Shatter Proof Glass
NN	Paper Tag
NH	Stainless Steel Tag
TPC	Mounting Clip for 1" & 2"
DM	Dial Markings
C4	Calibration Certificate

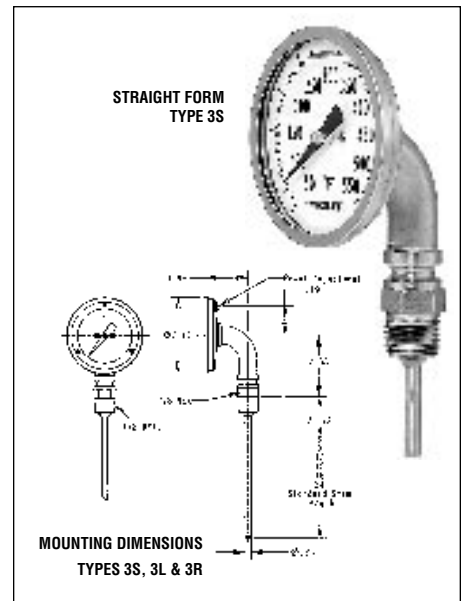

**SEPARABLE THERMOWELLS AVAILABLE
SEE PAGES 87 TO 90**

HOW TO ORDER

3 S 0 4 4 4 D R X

1. Basic 4-digit Catalog No. From Table Above _____
2. Stem Diameter: "4" = .250" O.D. (Standard); "5" = .375" O.D. (Extra Cost) _____
3. Thread Size: "4" = 1/2 NPT Male; "U" = 1/4 NPT Male (Extra Cost) _____
4. 2 Digit Range Code from Range Tables Above _____
5. Option(s): "X" = Non Required Option(s) Required (Extra Cost) Select code from above table _____