

**LIMITED SPACE WELLS**

Fits Weksler 3" and 5" bimetal thermometers with 2½" stem length. It is recommended that these be used only when space is such a critical factor that wells for 4" stem length bi-metals cannot be utilized.

**IMPORTANT NOTE:** The above limited space thermowells should not be used with Weksler 3" or 5" bimetals with the following ranges: 25/125°F, -40/120°F, 0/150°F, 50/500°F, 150/750°F, 0/50°C, -50/50°C, 0/300°C and 100/400°C. These ranges must use thermometers with 4" minimum stem length.

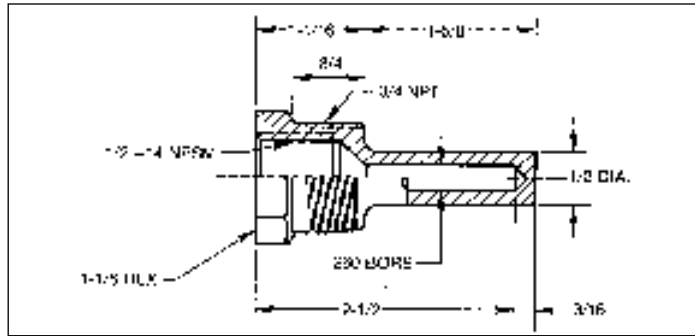

CATALOG NUMBERS				
	BRASS	STEEL	304 SS	316 SS
3/4 NPT	S3B1	S3S1	S3G1	S3J1
1 NPT	S4B1	S4S1	S4G1	S4J1

Brass wells are not recommended for installations involving high pressures and/or temperatures over 400°F.

**HEAVY DUTY THREADED WELLS**

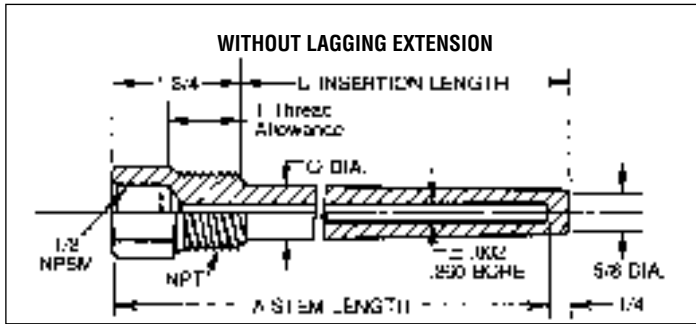

**3/4 NPT – CATALOG NUMBERS**

A	U	Q	STEEL	304 SS	316 SS
4	2½	—	S3S4H	S3G4H	S3J4H
6	4½	7/8	S3S6H	S3G6H	S3J6H
9	7½	7/8	S3S9H	S3G9H	S3J9H
12	10½	7/8	S3S2H	S3G2H	S3J2H
15	13½	7/8	S3S5H	S3G5H	S3J5H
18	16½	7/8	S3S8H	S3G8H	S3J8H
24	22½	7/8	S3STH	S3GTH	S3JTH

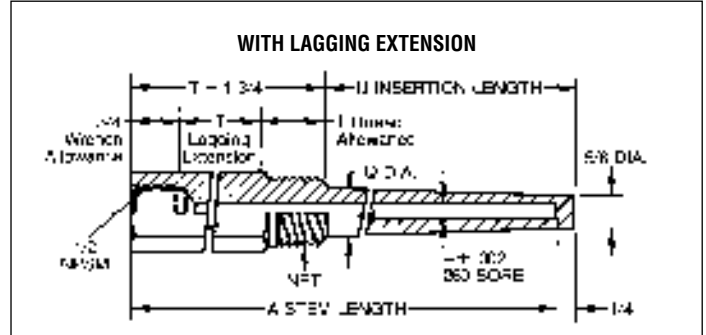

**3/4 NPT – CATALOG NUMBERS**

A	U	T	Q	STEEL	304 SS	316 SS
6	2½	2	7/8	L3S6H	L3G6H	L3J6H
9	4½	3	7/8	L3S9H	L3G9H	L3J9H
12	7½	3	7/8	L3S2H	L3G2H	L3J2H
15	10½	3	7/8	L3S5H	L3G5H	L3J5H
18	13½	3	7/8	L3S8H	L3G8H	L3J8H
24	19½	3	7/8	L3STH	L3GTH	L3JTH

**1 NPT – CATALOG NUMBERS**

A	U	Q	STEEL	304 SS	316 SS
4	2½	1½	S4S4H	S4G4H	S4J4H
6	4½	1½	S4S6H	S4G6H	S4J6H
9	7½	1½	S4S9H	S4G9H	S4J9H
12	10½	1½	S4S2H	S4G2H	S4J2H
15	13½	1½	S4S5H	S4G5H	S4J5H
18	16½	1½	S4S8H	S4G8H	S4J8H
24	22½	1½	S4STH	S4GTH	S4JTH

**1 NPT – CATALOG NUMBERS**

A	U	T	Q	STEEL	304 SS	316 SS
6	2½	2	1½	L4S6H	L4G6H	L4J6H
9	4½	3	1½	L4S9H	L4G9H	L4J9H
12	7½	3	1½	L4S2H	L4G2H	L4J2H
15	10½	3	1½	L4S5H	L4G5H	L4J5H
18	13½	3	1½	L4S8H	L4G8H	L4J8H
24	19½	3	1½	L4STH	L4GTH	L4JTH

Brass cap and chain available to keep bore clean when not in use.  
 .260" bore standard. If .385" bore is required:  
 (1) change the last digit of the catalog no. from H to L;  
 (2) "Q" diameter will be 1½" on all and diameter at the end of taper (bottom of well) will be 49/64".  
 For pressure and temperature rating use Table 2 on page 89.

**NOTE: ALL WEKSLER STANDARD THERMOWELLS ARE BORED FROM SOLID BAR STOCK.**