

STANDARD RANGES

- All Stainless Steel Construction
- External Recalibration Adjustment
- White dial with black markings
- Accurate to ±1% of Scale Range
- Gasketed Glass Face
- Case is sealed to exclude dirt, dust and moisture
- 3" and 5" dial sizes
- Angularly adjustable frame permits positioning of dial to accommodate viewing requirements

3" AND 5" DIAL SIZE CATALOG NUMBERS

STEM LENGTH	FIXED THREAD		UNION CONNECTED	
	3"	5"	3"	5"
2½"	CF02	AF02	CU02	AU02
4"	CF04	AF04	CU04	AU04
6"	CF06	AF06	CU06	AU06
9"	CF09	AF09	CU09	AU09
12"	CF12	AF12	CU12	AU12
15"	CF15	AF15	CU15	AU15
18"	CF18	AF18	CU18	AU18
24"	CF24	AF24	CU24	AU24

NOTE: Union connected types must be used with thermowells, longer length available on special order.

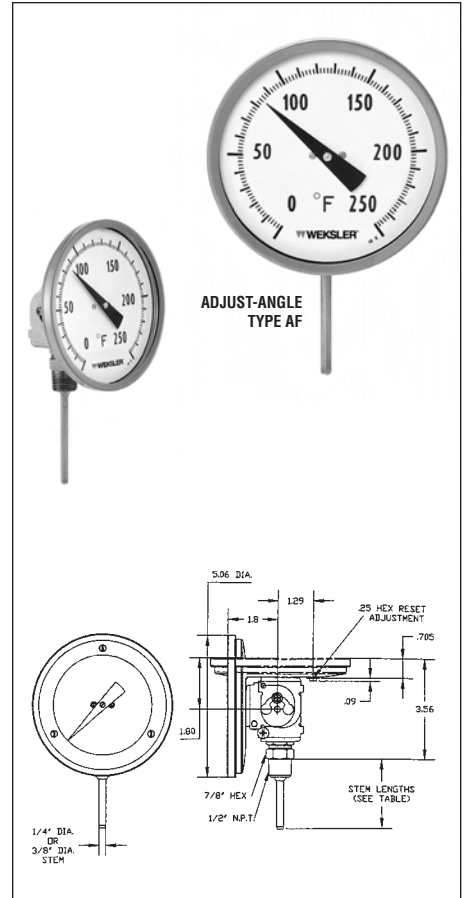

STANDARD RANGES

CODE	Fahrenheit
FC	-80 to 120°F
FE	-40 to 120°F
FG	0 to 150°F
FJ	0 to 200°F
FL	0 to 250°F
FM	30 to 240°F
FN	30 to 130°F †
FR	50 to 300°F
FS	50 to 400°F
FT	50 to 550°F
FX	150 to 750°F †
FY	200 to 1000°F* †
Celsius	
CD	-50 to 50°C
CJ	0 to 100°C
CM	-10 to 110°C
CN	0 to 50°C †
CR	0 to 150°C
CS	0 to 200°C
CU	0 to 300°C
CX	50 to 450°C †
CY	100 to 550°C* †

CODE	DUAL SCALE	
	Fahrenheit (on outside)	Celsius (on inside)
DE	-40/120°F and	-40/50°C
DF	40/160°F and	-40/70°C
DN	30/130°F and	0/55°C †
DJ	0/200°F and	-20/94°C
DL	0/250°F and	-20/120°C
DR	50/300°F and	10/150°C
DS	50/400°F and	10/200°C
DT	50/550°F and	10/290°C
DX	100/800°F* and	40/430°C †
DY	200/1,000°F and	100/550°C* †

*Not recommended for continuous service above 800°F (425°C). For such temperatures see pg. 63.
†Minimum stem length for these ranges 4".

**SEPARABLE THERMOWELLS AVAILABLE
SEE PAGES 59 - 63**

OPTIONAL FEATURES	
CODE	Description
EL	Liquid Filling for Catalog No's AF, 3A, 5A only
PD	Plastic Window
SG	Shatter Proof Glass
NN	Paper Tag
NH	Stainless Steel Tag
DM	Dial Markings
C4	Calibration Certificate

HOW TO ORDER

A F 0 6 4 4 F M X

1. Basic 4-digit Catalog No. From Table Above _____
2. Stem Diameter: "4" = .250"O.D. (Standard); "5" = .375"O.D. (Extra Cost) _____
3. Thread Size: "4" = ½ NPT Male (AF Series); "U" = ½ NPT Male Swivel Nut (AU Series) _____
4. 2 Digit Range Code from Range Tables Above _____
5. Option(s): "X" = None Required; "9" = Option(s) Required (Extra Cost) _____

If option(s) are required specify: Plastic Face, Shatterproof Glass Face, Paper Tag, Stainless Steel Tag